



The RuggedSwitch™ RS900 is a 9-port industrially hardened, fully managed, Ethernet switch specifically designed to operate reliably in electrically harsh and climatically demanding environments.

The RS900 provides a high level of immunity to electromagnetic interference and heavy electrical surges typical of environments found on plant floors or in curb side traffic control cabinets. An operating temperature range of -40 to +85°C (-40 to +185°F) coupled with hazardous location certification (Class 1 Division 2) allows the RS900 to be placed in almost any location.

The RS900 is packaged in a compact, galvanized steel enclosure that allows either DIN or panel mounting for efficient use of cabinet space. The RS900 provides an integrated power supply with a wide range of voltages (88-300VDC or 85-264VAC) for worldwide operability or dual-redundant, reversible polarity, 24VDC and 48VDC power supply inputs for high availability applications requiring dual or backup power inputs.

The RS900's superior ruggedized design coupled with the embedded Rugged Operating System (ROS™) provides improved system reliability and advanced networking features making it ideally suited for creating Ethernet networks for mission-critical, real-time, control applications.

The versatility and wide selection of fiber optics allows the RS900 to be used in a variety of applications. The RS900 provides up to three 100Mbps fiber optical Ethernet ports for creating a fiber optical backbone with high noise immunity and long haul connectivity.

All RuggedCom products are backed by a five year warranty and unsurpassed technical support.

Features and Benefits

Ethernet Ports

- Up to 9 Ports: 6 Base 10/100BaseTX ports with option for 3 additional Fiber or Copper ports
- Industry standard fiber optical connectors: LC, SC, ST, MTRJ
- Multimode and Singlemode optical transceivers
- Long haul optics allow distances up to 90km

Cyber Security Features

- Multi-level user passwords
- SSH/SSL encryption
- Enable/disable ports, MAC based port security
- Port based network access control (802.1x)
- VLAN (802.1q) to segregate and secure network traffic
- Radius centralized password management
- SNMPv3 encrypted authentication and access security

RuggedRated™ for Reliability in Harsh Environments

- Immunity to EMI and heavy electrical surges
 - Exceeds IEEE 61800-3 (variable speed drive systems)
 - Exceeds IEC 61000-6-2 (generic industrial)
 - Exceeds NEMA TS-2 (traffic control equipment)
- Hazardous Location Certification: Class 1 Division 2
- -40 to +85°C operating temperature (no fans)
- Conformal coated printed circuit boards (optional)
- 20 AWG galvanized steel enclosure

Rugged Operating System (ROS™) Features

- Simple plug and play operation - automatic learning, negotiation, and crossover detection
- RSTP (802.1w) and Enhanced Rapid Spanning Tree (eRSTP™) network fault recovery (<5ms)
- Quality of Service (802.1p) for real-time traffic
- VLAN (802.1q) with double tagging and GVRP support
- Link aggregation (802.3ad)
- IGMP Snooping for multicast filtering
- Port Rate Limiting and Broadcast Storm Limiting
- Port configuration, status, statistics, mirroring, security
- Industrial automation features (eg. Modbus)

Management Tools

- Web-based, Telnet, CLI management interfaces
- SNMP v1/v2/v3
- Remote Monitoring (RMON)
- Rich set of diagnostics with logging and alarms

Universal Power Supply Options

- Fully integrated power supply
- Universal high-voltage range: 88-300VDC or 85-264VAC
- Dual low-voltage DC inputs: 24VDC (9-36VDC) or 48VDC (36-59VDC)
- Terminal blocks for reliable maintenance free connections
- CSA/UL 60950 safety approved to +85°C



RuggedSwitch™ RS900

Optional Ports:

- ▶ Up to 3 Ports
- ▶ Fast 10/100BaseTx
- ▶ Fiber Optical (MMF/SMF)
- ▶ SC, ST, LC and MTRJ
- ▶ Bi-directional (single strand)
- ▶ Distances up to 90km

Rugged Construction:

- ▶ 20 AWG. galvanized steel enclosure
- ▶ Conformal coating (optional)

Hazardous Location Certification

- ▶ Class1, Division2

Integrated Power Supply

- ▶ Universal high-voltage range: 88-300VDC or 85 - 264VAC
- ▶ Popular low voltage DC ranges: 24VDC (9-36VDC), 48VDC (36-59VDC)
- ▶ Dual Isolated DC power inputs

Mounting Options

- ▶ Din Rail
- ▶ Panel Mount

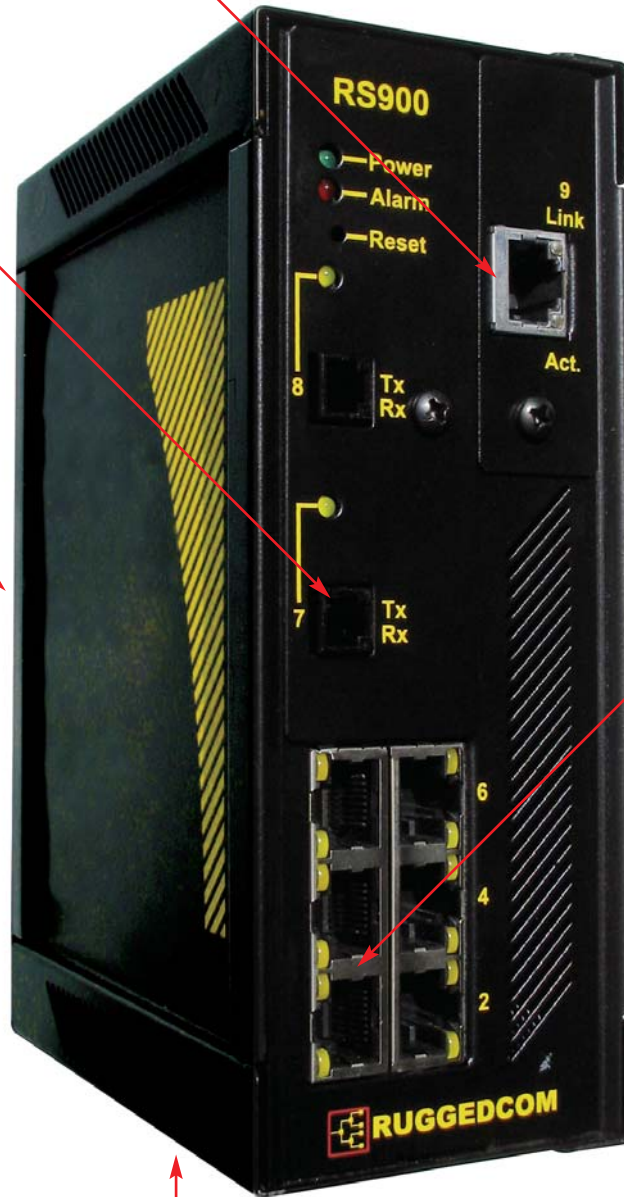

Operating Temperature

- ▶ -40°C to +85°C
- ▶ No Fans

Fast Ethernet Ports:

- ▶ 6 - Fast Ethernet Ports (10/100BaseTX)

Critical Alarm Relay

- ▶ Form-C failsafe contact relay: 1A@30VDC

ROS™ Features

Cyber Security

Cyber security is an urgent issue in many industries where advanced automation and communications networks play a crucial role in mission critical applications and where high reliability is of paramount importance. Key ROS™ features that address security issues at the local area network level include:

- **Passwords** - Multi-level user passwords secures switch against unauthorized configuration
- **SSH / SSL** - Extends capability of password protection to add encryption of passwords and data as they cross the network
- **Enable / Disable Ports** - Capability to disable ports so that traffic can not pass
- **802.1q VLAN** - Provides the ability to logically segregate traffic between predefined ports on switches
- **MAC Based Port Security** - The ability to secure ports on a switch so only specific Devices / MAC addresses can communicate via that port
- **802.1x Port Based Network Access Control** - The ability to lock down ports on a switch so that only authorized clients can communicate via this port
- **Radius** - Provides centralized password management
- **SNMPv3** - encrypted authentication and access security

The ROS™ cyber security features are included to help address the various industry specific security standards such as NERC CIP, ISA S99, AGA 12, IEC 62443, ISO 17799:2005 and PCSRF SPP-ICS.

Enhanced Rapid Spanning Tree Protocol (eRSTP™)

RuggedCom eRSTP allows the creation of fault-tolerant ring and mesh Ethernet networks that incorporate redundant links that are 'pruned' to prevent loops. eRSTP yields worst-case fault recovery¹ of 5ms times the 'bridge diameter' and allows rings of up to 80 switches. For example, a ring of ten switches will have fault recovery times under 50ms. eRSTP implements both STP and RSTP to ensure interoperability with commercial switches unlike other proprietary 'ring' solutions.

Quality of Service (IEEE 802.1p)

Some networking applications such as real-time control or VoIP (voice over IP) require predictable arrival times for Ethernet frames. Switches can introduce latency in times of heavy network traffic due to the internal queues that buffer frames and then transmit on a first come first serve basis. ROS™ supports 'Class of Service' in accordance with IEEE 802.1p that allows time critical traffic to jump ahead to the front of the queue thus minimizing latency and reducing jitter to allow such demanding applications to operate correctly. ROS™ allows priority classification by port, tags, MAC address, and IP type of service (TOS).

A configurable "weighted fair queuing" algorithm controls how frames are emptied from the queues.

VLAN (IEEE 802.1q)

Virtual local area networks (VLAN) allow the segregation of a physical network into separate logical networks with independent broadcast domains. A measure of security is provided since hosts can only access other hosts on the same VLAN and traffic storms are isolated. ROS™ supports 802.1q tagged Ethernet frames and VLAN trunks. Port based classification allows legacy devices to be assigned to the correct VLAN. GVRP support is also provided to simplify the configuration of the switches on the VLAN.

Link Aggregation (802.3ad)

The link aggregation feature provides the ability to aggregate several Ethernet ports into one logical link (port trunk) with higher bandwidth. This provides an inexpensive way to set up a high speed backbone to improve network bandwidth. This feature is also known as "port trunking", "port bundling", "port teaming", and "ethernet trunk".

IGMP Snooping

ROS uses IGMP snooping (Internet Group Management Protocol v1&v2) to intelligently forward or filter multicast traffic streams (e.g. MPEG video) to or from hosts on the network. This reduces the load on network trunks and prevents packets from being received on hosts that are not involved. ROS™ has a very powerful implementation of IGMP snooping that:

- Can be enabled on a per VLAN basis.
- Detects and filters all multicast streams regardless of whether subscribers exist.
- Supports "router-less" operation by supporting an "active" mode.
- Restores traffic streams immediately after an RSTP topology change.

SNMP (Simple Network Management Protocol)

SNMP provides a standardized method for network management stations the ability to interrogate devices from different vendors. SNMP versions supported by ROS™ are v1, v2c, and v3. SNMPv3 in particular provides security features (such as authentication, privacy, and access control) not present in earlier SNMP versions. ROS™ also supports numerous standard MIBs (Management Information Base) allowing for easy integration with any network management system (NMS).

¹ eRSTP fault recovery times may be approximated as follows:

For 100 Mbps, fault recovery performance is <5ms/hop

For 1,000 Mbps, fault recovery performance is <5ms/hop + 20ms

ROS™ Features

SNMP (Simple Network Management Protocol) (cont'd)

A feature of SNMP supported by ROS™ is the ability to generate "traps" upon system events. A NMS can record traps from multiple devices providing a powerful network troubleshooting tool. RuggedVue™ is RuggedCom's NMS that provides graphical visualization of the network and is fully integrated with all RuggedCom products.

SNTP (Simple Network Time Protocol)

SNTP automatically synchronizes the internal clock of all ROS™ devices on the network. This allows for correlation of time stamped events for troubleshooting.

SCADA and Industrial Automation

ROS™ contains features that optimize network performance and simplify switch management based on the unique requirements found in SCADA and industrial automation applications. Features such as Modbus TCP management for retrieval of switch data using the ubiquitous Modbus protocol and DHCP Option 82, a Rockwell Automation ODVA requirement for IP address assignment based on the location of the end device, provide capabilities not found in typical "commercial" or "office grade" Ethernet switches.

Port Based Network Access Control (802.1x)

ROS™ supports the IEEE 802.1x standard that defines a mechanism for port-based network access control which provides a means of authenticating and authorizing devices attached to LAN ports.

Port Rate Limiting

ROS™ supports configurable rate limiting per port to limit unicast and multicast traffic. This can be essential to managing precious network bandwidth for service providers. It also provides edge security for denial of service (DOS) attacks.

Broadcast Storm Filtering

Broadcast storms wreak havoc on a network and can cause attached devices to malfunction. This could be disastrous on a network with mission critical equipment. ROS™ limits this by filtering broadcast frames with a user-defined threshold.

Loss of Link Management

Some intelligent electronic devices (IEDs) have dual fiber optic ports with automatic failover to a backup port should the primary fail. ROS™ ensures this mechanism works reliably under all failure modes by appropriately disabling link signals when required. ROS™ also flushes learned MAC addresses to ensure the failover occurs quickly.

Port Mirroring

ROS™ can be configured to duplicate all traffic on one port to a designated mirror port. When combined with a network analyzer, this can be a powerful troubleshooting tool.

Port Configuration and Status

ROS™ allows individual ports to be 'hard' configured for speed, duplex, auto-negotiation, flow control and more. This allows proper connection with devices that do not negotiate or have unusual settings. Detailed status of ports with alarm and SNMP trap on link problems aid greatly in system troubleshooting.

Port Statistics and RMON (Remote Monitoring)

ROS™ provides continuously updating statistics per port that provide both ingress and egress packet and byte counters as well as detailed error figures. Also provided is full support for the RMON statistics, history, alarms, and event groups. RMON allows for very sophisticated data collection, analysis and detection of traffic patterns.

Event Logging and Alarms

ROS™ records all significant events to a non-volatile system log allowing forensic troubleshooting. Events include link failure and recovery, unauthorized access, broadcast storm detection, and self-test diagnostics among others. Alarms provide a snapshot of recent events that have yet to be acknowledged by the network administrator. An external hardware relay is de-energized during the presence of critical alarms allowing an external controller to react if desired.

HTML Web Browser and Telnet User Interfaces

ROS™ provides a simple, intuitive user interface for configuration and monitoring via a standard graphical web browser or via Telnet. All system parameters include detailed on-line help to make setup a breeze. ROS™ , presents a common look and feel and standardized configuration process allowing easy migration to other RuggedCom managed products.

Configuration via ASCII Text File

All configuration parameters are stored in an ASCII formatted text file that can easily be transferred via TFTP or Xmodem. The configuration file can be saved for backup purposes and easily manipulated by a text editor. The same text file can be downloaded to the switch at a later date in order to re-configure or restore a previous configuration.

Command Line Interface (CLI)

A command line interface can be used in conjunction with remote shell to automate data retrieval, configuration updates, and firmware upgrades. A powerful SQL-like capability allows expert users the ability to selectively retrieve or manipulate any parameters the device has to offer.

EMI and Environmental Type Tests

NEMA TS-2 Requirements			
Test	Description	Levels	Performance Criteria*
TS-2 1998, Section 2, para 2.2.7.3	Temperature: Low Temperature/Low Voltage	89.0 VAC @ -34°C	EUT Continued to function properly during and following all temperature and humidity testing
TS-2 1998, Section 2, para 2.2.7.4	Temperature: Low Temperature/High Voltage	135.0VAC @ -34°C	
TS-2 1998, Section 2, para 2.2.7.5	Temperature: High Temperature/High Voltage	135.0VAC @ + 75°C	
TS-2 1998, Section 2, para 2.2.7.6	Temperature: High Temperature/Low Voltage	89.0VAC @ + 75°C	
TS-2 1998, Section 2 para. 2.2.8.4	Vibration Endurance Test	0.5g @ 30Hz for 1hr on all three planes	EUT functioned properly following test procedure. No physical damage.
TS-2 1998, Section 2, para 2.1.10	Mechanical Shock	+/-10g half sine wave for 11msec on all three planes	EUT functioned properly following test procedure. No physical damage.
TS-2 1992, Section 2, para. 2.1.6.1	Electrical Transients: High Repetition Noise (AC Terminals)	One +/-300VDC pulse every other cycle once every 3 seconds across 360 ° of line cycle (2500W peak)	EUT functioned properly during and following test procedure. No damage
TS-2 1998, Section 2 para. 2.1.6.2	Electrical Transients: Low-Repetition High Energy (AC Terminals)	One +/-600VDC pulse every second, randomly distributed across 360 ° of line cycle. Ten pulses total.	EUT functioned properly during and following test procedure. No damage
TS-2 1998, Section 2, para 2.1.7	Electrical Transients: I/O Terminals	One +/-300VDC pulse every second, minimum 5 pulses per port	EUT functioned properly during and following test procedure. No damage
TS-2 1992, Section 2, para. 2.1.8	Electrical Transients: Nondestruct Transient Immunity (AC Terminals)	One +/-1000VDC pulse every two seconds, 3 per each polarity.	EUT functioned properly following test procedure. No damage

IEC 61000-6-2 EMC Generic Standard: Immunity for Industrial Environments					
Test	Description	Levels	RuggedCom Test Level	Performance Criteria*	
IEC 61000-4-2	ESD	Enclosure Contact	+/- 4kV	+/- 8kV	B
		Enclosure Air	+/- 8kV	+/- 15kV	B
IEC 61000-4-3	Radiated RFI	Enclosure ports	10 V/m, 80 to 1000Mhz	20V/m	A
IEC 61000-4-4	Burst (Fast Transient)	Signal ports	+/- 1kV @ 5kHz	+/- 4kV @ 2.5kHz	B
		D.C Power ports	+/- 2kV @ 5kHz	+/- 4kV	B
		A.C. Power ports	+/- 2kV @ 5kHz	+/- 4kV	B
IEC 61000-4-5	Surge	Signal ports	+/- 1kV line-to-earth	+/- 2kV line-to-earth, +/- 2kV line-to-line	B
		D.C Power ports	+/- 0.5kV line-to-earth/line	+/- 4kV line-to-earth, +/- 2kV line-to-line	B
		A.C. Power ports	+/- 2kV line-to-earth, +/- 1kV line-to-line	+/- 4kV line-to-earth, +/- 2kV line-to-line	B
IEC 61000-4-6	Induced (Conducted) RFI	Signal ports	10V @ 0, 5-80 MHz	10V @ 0, 5-80 MHz	A
		D.C Power ports	10V @ 0, 5-80 MHz	10V @ 0, 5-80 MHz	A
		A.C. Power ports	10V @ 0, 5-80 MHz	10V @ 0, 5-80 MHz	A
		Earth ground ports	10V @ 0, 5-80 MHz	10V @ 0, 5-80 MHz	A
IEC 61000-4-8	Magnetic Field	Enclosure ports	30 A/m @ 50, 60 Hz	40 A/m continuous, 1000 A/m for 1s	A
IEC 61000-4-11	Voltage Dips	A.C. Power ports	30% reduction for 0.5 period	30% for 1 period	B
			>95% reduction for 250 periods	100% for 5 periods, 100% for 50 periods	C
IEC 60255-5	Dielectric Strength	Signal ports	2kVac (Fail-Safe Relay output)	2kVac (Fail-Safe Relay output)	N/A
		D.C. Power ports	2kVac	2kVac	N/A
		A.C. Power ports	2kVac	2kVac	N/A
IEC 60255-5	H.V. Impulse	Signal ports	5kV (Fail-Safe Relay output)	5kV (Fail-Safe Relay output)	N/A
		D.C. Power ports	5kV	5kV	N/A
		A.C. Power ports	5kV	5kV	N/A

Environmental Type Tests				
Test	Description	Test Levels	Severity Levels	
IEC 60068-2-1	Cold Temperature	Test Ad	-40°C, 16 Hours	N/A
IEC 60068-2-2	Dry Heat	Test Bd	+85°C, 16 Hours	N/A
IEC 60068-2-30	Humidity (Damp Heat, Cyclic)	Test Db	95% (non-condensing), 55°C, 6 cycles	N/A
IEC 60255-21-1	Vibration	Tests Fc	2g @ (10 - 150) Hz	Class 2 ¹
IEC 60255-21-2	Shock	Tests Ea	30g @ 11mS	Class 2

Notes: 1. Class 2 refers to "Measuring relays and protection equipment for which a very high security margin is required or where the vibration levels are very high, (e.g. shipboard application and for severe transportation conditions)"

Technical Specifications

Power Supply

- Power Consumption: 10W MAX
- 24VDC: 9-36 VDC, 0.4A
- 48VDC: 36-59 VDC, 0.2A
- HI Voltage AC/DC: 88-300VDC, 85-264VAC, 0.1A

Critical Alarm Relay

- Form-C failsafe contact relay: 1A@30VDC

Physical

- Height: 7.4"
- Width: 2.6"
- Depth: 5.0"
- Weight: 2.7lbs
- Ingress Protection: IP40 (1mm objects)
- Enclosure: 20 AWG galvanized steel enclosure
- Mounting: DIN rail or panel mounted

Switch Properties

- Switching method: Store & Forward
- Switching latency: 8 us (100Mbps)
- Switching bandwidth: 1.8Gbps
- MAC address table size: 16kbytes
- Priority Queues: 4
- Frame buffer memory: 1 Mbit
- VLANs: 64
- IGMP multicast groups: 256
- Port rate limiting: 128kbps, 256, 512, 4, 8Mbps
- No head of line blocking

Approvals

- Hazardous Locations: Class 1, Division 2
- ISO: Designed and manufactured using a ISO9001: 2000 certified quality program
- CE Marking
- Emissions: FCC Part 15 (Class A), EN55022 (CISPR22 Class A)
- Safety: cCSAus (Compliant with CSA C22.2 No. 60950, UL 60950, EN60950)
- Laser Eye Safety (FDA/CDRH): Complies with 21 CFR Chapter1, Subchapter J.

Warranty

- 5 Years-Applicable to design or manufacturing related product defects.

Network Management

- ROSVue HTTP graphical web-based
- SNMP v1, v2c, v3
- Telnet, VT100
- Command Line Interface (CLI)

IEEE Compliance

- 802.3-10BaseT
- 802.3u-100BaseTX, 100BaseFX
- 802.3x-Flow Control
- 802.3z-1000BaseLX
- 802.3ab-1000BaseTX
- 802.3ad-Link Aggregation
- 802.1d-MAC Bridges
- 802.1d-Spanning Tree Protocol
- 802.1p-Class of Service
- 802.1q-VLAN Tagging
- 802.1w-Rapid Spanning Tree Protocol
- 802.1x-Port Based Network Access Control

IETF RFC Compliance

- RFC768-UDP
- RFC783-TFTP
- RFC791-IP
- RFC792-ICMP
- RFC793-TCP
- RFC826-ARP
- RFC854-Telnet
- RFC894-IP over Ethernet
- RFC1112-IGMP v1
- RFC1519-CIDR
- RFC1541-DHCP (client)
- RFC2030-SNTP
- RFC2068-HTTP
- RFC2236-IGMP v2
- RFC2284-EAP
- RFC2475-Differentiated Services
- RFC2865-Radius
- RFC3414-SNMPv3-USM
- RFC3415-SNMPv3-VACM

IETF SNMP MIBS

- RFC1493-BRIDGE-MIB
- RFC1907-SNMPv2-MIB
- RFC2012-TCP-MIB
- RFC2013-UDP-MIB
- RFC2578-SNMPv2-SMI
- RFC2579-SNMPv2-TC
- RFC2819-RMON-MIB
- RFC2863-IF-MIB
- draft-ietf-bridge-rstpmib-03-BRIDGE-MIB
- draft-ietf-bridge-bridgemib-smiv2-03-RSTP-MIB
- IANAifType-MIB

Fiber Specifications and Mechanical Drawing

Fiber Optical Specifications				
Parameter	Fiber Port Type			
	Multimode	Singlemode		
Mode	Multimode	Singlemode		
Connectors	MTRJ / ST / SC / LC	LC / SC / ST		
Typical Dist. (km)	2	20	50	90
Optical Wavelength (nm)	1310	1310		
Cable Size Core/Cladding (um)	50 or 62.5/125	8 or 9/125		
Tx Power (dBm)	-15.7	-15.5	-2.5	2.5
Rx Sensitivity (dBm)	-33.5	-32	-37	-39
Typical Budget (dB)	17	16.5	34.5	41.5

Longer segment lengths dependent on fiber specifications. Consult factory for further details.

SIDE MOUNT WITH
RS8000 PANEL
MOUNT BRACKETS

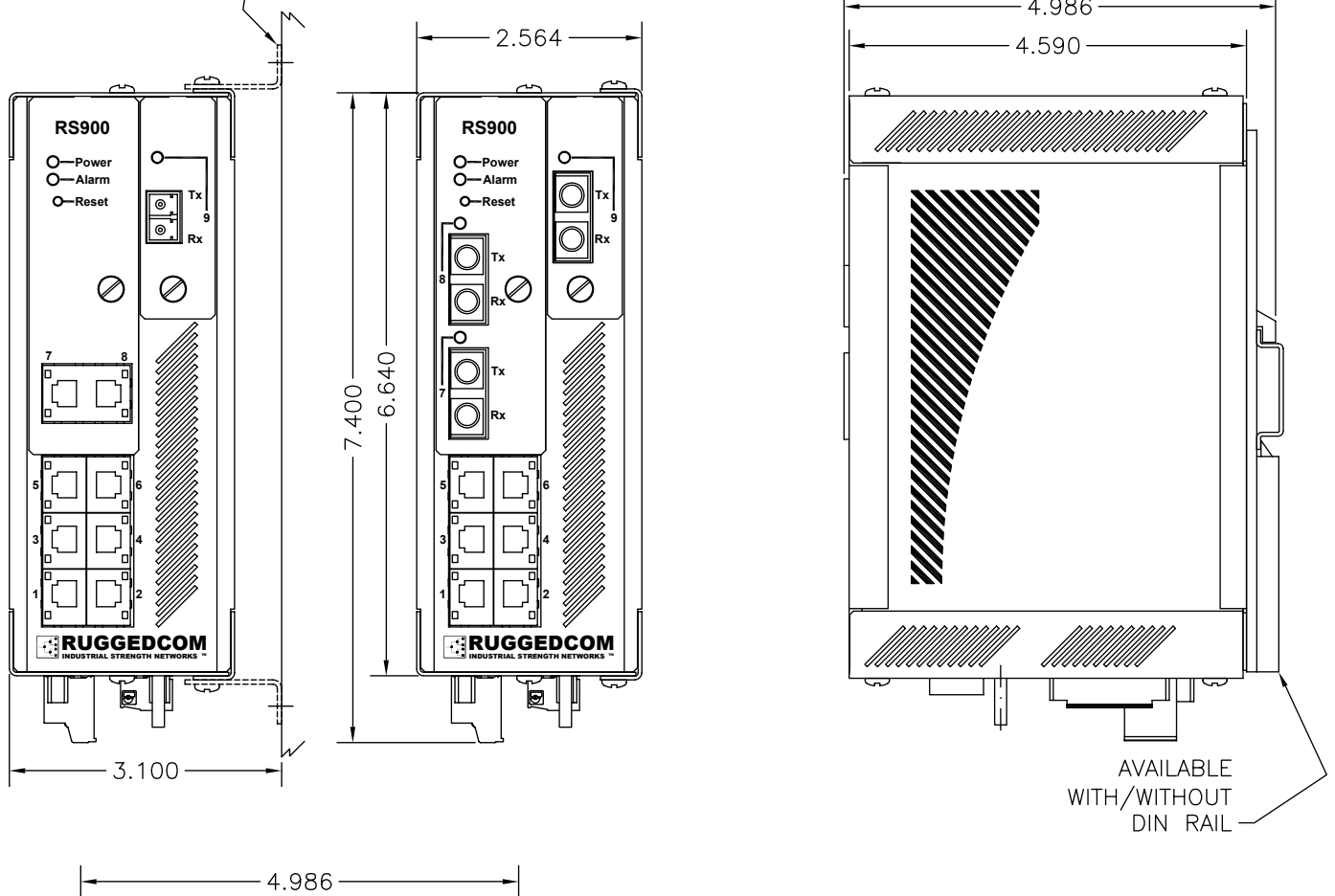

Order Codes

RS900 - - -
PS M P7P8P9

PS: Power Supply

- 24 = 24 VDC (9-36 VDC)
- 48 = 48 VDC (36-59 VDC)
- HI = 85-264VAC or 88-300VDC

M: Mounting Option

- D = DIN RAIL
- P = PANEL MOUNT
- N = NONE

P7, P8, P9: Port 7-9 Options

- 00 = No port
- TX = 10/100TX (if selected, port 7&8 must both be TX)
- MJ = Multimode MTRJ
- MC = Multimode SC
- MT = Multimode ST
- ML = Multimode LC
- T2 = Singlemode ST, Standard 20km
- L2 = Singlemode LC, Standard 20km
- L5 = Singlemode LC, Intermediate Reach 50km
- L9 = Singlemode LC, Long Reach 90km
- C2 = Singlemode SC, Standard 20km
- C5 = Singlemode SC, Intermediate Reach 50km
- C9 = Singlemode SC, Long Reach 90km

Example Order Codes

- RS900-24-D-000000
- RS900-24-D-TXTX00
- RS900-48-P-TXTXMT
- RS900-HI-D-C20000
- RS900-HI-D-L2L200
- RS900-HI-N-C5C5C9

Options

82-01-0002 - Conformal Coating

RuggedCom Inc.

30 Whitmore Road

Woodbridge, Ontario, Canada L4L 7Z4

Tel: (905) 856-5288 Fax: (905) 856-1995

Toll Free: (888) 264-0006

Technical Support Center: (866) 922-7975 or (954) 922-7975

© 2006 RuggedCom Inc.

RuggedSwitch is a trademark of RuggedCom Inc.

Ethernet is a trademark of the Xerox Corporation.

Patent Pending

All specifications in this document are subject to change without notice.

Rev 2-E

For additional information on our products and services, please visit our web site at: www.ruggedcom.com